



Installation and Operation Instructions

HeatBloC

MC42 / MC43 / MC44

DN 25 / DN 32

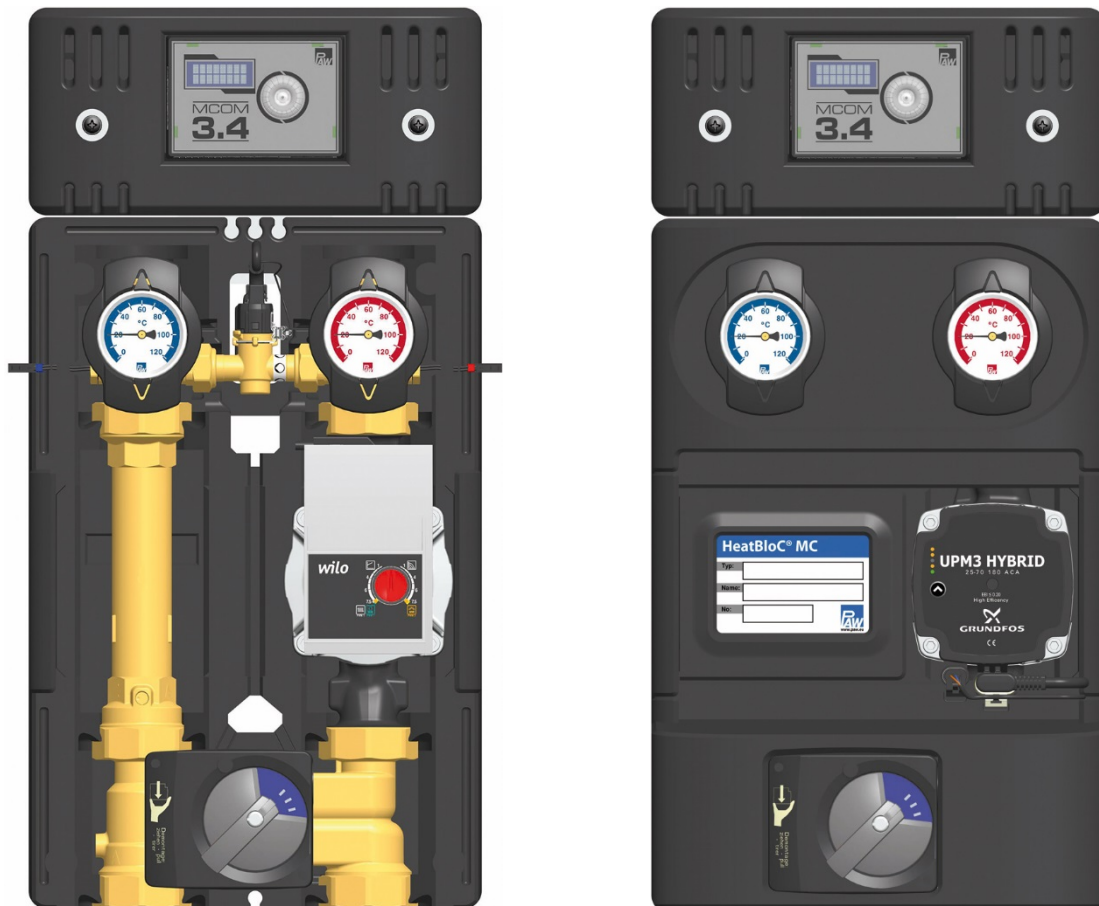

Contents

1	General Information	4
1.1	Scope of these instructions	4
1.2	Designated use	4
2	Safety instructions	5
3	Product description	6
3.1.1	Equipment.....	6
3.1.2	Function	7
3.2	3-way mixing valve [specialist]	8
3.3	Pump [specialist]	10
3.3.1	Pump settings	10
3.3.2	Pump settings Grundfos UPM3 Hybrid	10
3.3.3	Pump settings Wilo-Yonos PARA RSTG	11
3.4	Check valve	11
3.5	Actuator.....	12
4	Change of the flow line [specialist]	13
4.1	Conversion of the mixing valve.....	14
5	Assembly and installation [specialist]	16
5.1	Installation and commissioning of the HeatBloC.....	16
5.2	Cabling.....	19
5.3	Accessories.....	21
5.3.1	Connection set (not included in the scope of delivery).....	21
5.3.2	Communication set (not included in the scope of delivery)	21
5.3.3	Cutting-ring compression fitting (not included in the scope of delivery).....	22
5.3.4	Wall bracket set for wall assembly (not included in the scope of delivery)	22



6	Scope of delivery [specialist]	23
6.1	Insulation and controller DN 25	23
6.2	Hydraulics DN 25	24
6.3	Insulation and controller DN 32	25
6.4	Hydraulics DN 32	26
7	Technical data	27
7.1	Dimensional drawing DN 25.....	28
7.2	Dimensional drawing DN 32.....	28
7.3	Pressure drop and pump characteristic curves MC42	29
7.4	Pressure drop and pump characteristic curves MC43/MC44.....	30

Item no. 99453x0x3x-mub-en – Version V02 – Issued 2017/02

Translation of the original instructions

We reserve the right to make technical changes without notice!

Printed in Germany – Copyright by PAW GmbH & Co. KG

PAW GmbH & Co. KG

Böcklerstr. 11

D-31789 Hameln, Germany

1 General Information



Carefully read these instructions before installation and commissioning.
Save these instructions in the vicinity of the installation for future reference.

1.1 Scope of these instructions

These instructions describe the installation, commissioning, function and the operation of the mixed HeatBloC MC42 / MC43 / MC44 in DN 25 and DN 32.

For other components of the installation, such as the pump, the controller or the modular distribution manifold, please observe the instructions of the corresponding manufacturer.

The chapters called [specialist] are intended for specialists only.

1.2 Designated use

The HeatBloC may only be used in heating circuits taking into consideration the technical limit values indicated in these instructions.

The HeatBloC must **not** be used in drinking water applications.

Improper usage of the HeatBloC excludes any liability claims.

Only use PAW accessories with the HeatBloC.

This product complies with the relevant directives and is therefore labelled with the CE mark.

The Declaration of Conformity is available upon request. Please contact the manufacturer.

The wrapping materials are made of recyclable materials and can be disposed of with recyclable materials.

2 Safety instructions

The installation and commissioning as well as the connection of electrical components require technical knowledge commensurate with a recognised vocational qualification as a fitter for plumbing, heating and air conditioning technology, or a profession requiring a comparable level of knowledge [specialist]. The following must be observed during installation and commissioning:

- relevant local and national regulations
- accident prevention regulations of the professional association
- instructions and safety instructions of this manual

	<p>CAUTION</p> <p>Personal injury and damage to property!</p> <p>The HeatBloC must only be used in heating circuits filled with heating water according to VDI 2035 / Ö-Norm H 5195-1.</p> <p>The HeatBloC must not be used in drinking water applications.</p>
--	--

NOTICE

Material damage due to mineral oils!

Mineral oil products cause lasting damage to seals made of EPDM, whereby the sealant properties get lost. We do not assume liability nor provide warranty for damage to property resulting from sealants damaged in this way.

- It is imperative to avoid that EPDM gets in contact with substances containing mineral oils.
- Use a lubricant based on silicone or polyalkylene and free from mineral oils, such as Unisilikon L250L and Syntheso Glep 1 of the Klüber company or a silicone spray.

3 Product description

The HeatBloC MC is a preassembled group of fittings for heating circuits. The integrated pump can be isolated by means of ball valves and can thus be maintained without draining of the system.

The nominal value for the differential pressure between the flow and the return is adjusted at the controller. On this basis, the controller regulates the pump. Thus, the hydraulic balancing at the distribution manifold is assured and an energy-saving operation of the pump is guaranteed at any time.

The PAW HeatBloC must be either installed on a PAW modular distribution manifold or a PAW wall bracket.

For the function of a MC system, **one** connection set (wall power supply, item no. 1398700) is necessary. The connection set is not included in the scope of delivery.

3.1.1 Equipment

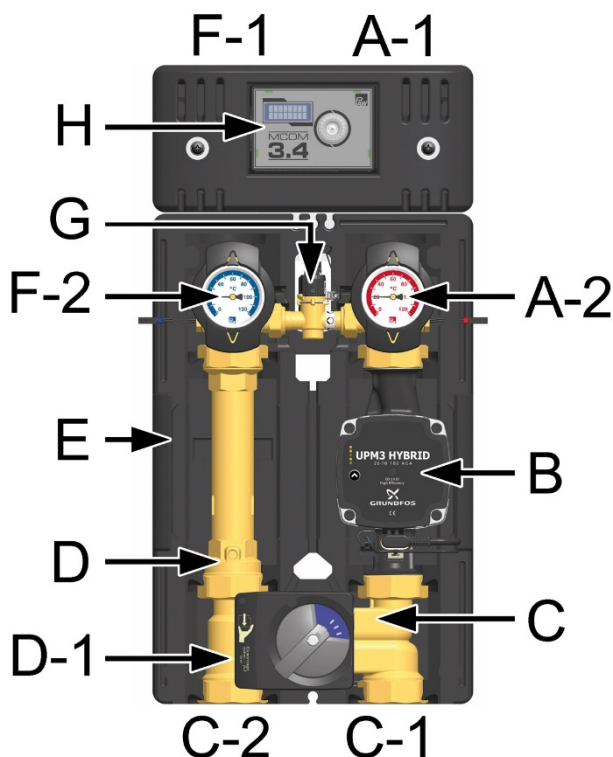

- A-1 Flow to the consumer circuit
- A-2 Flow ball valve with temperature sensor T_V and thermometer
- B Heating pump
- C 3-way mixing valve with actuator
MC43/44: with bypass 0-50 %
- C-1 Flow from the heat generator
- C-2 Return to the heat generator
- D-1 Non-return valve, can be opened
- D Return pipe with check valve, can be opened
- E Design insulation according to EnEV directive
- F-1 Return from the consumer circuit
- F-2 Return ball valve with temperature sensor T_R and thermometer
- G Differential pressure sensor
- H Controller MCom

3.1.2 Function

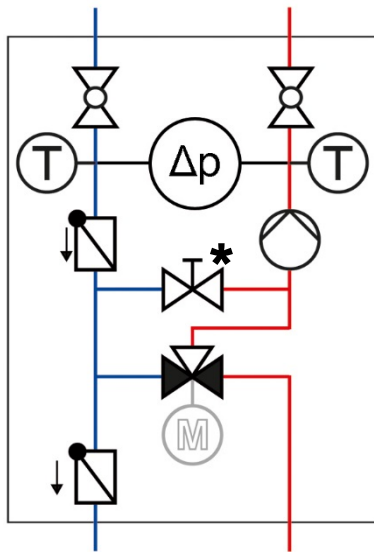

MC42 / MC43 / MC44 –

HeatBloC with 3-way mixing valve

The flow temperature of the heating circuit is controlled by the integrated mixing valve.

Hot water from the boiler and cold return water are mixed to obtain the desired flow temperature of the heating circuit.

The mixing valve is adjusted by an external controller (HeatBloC MC42 and MC44) or an internal controller (HeatBloC MC43) in combination with the electrical actuator.

*bypass for MC43 and MC44 only



Application ranges:

- Installations with several HeatBloCs and different flow temperatures (radiators and radiant floor heating)
- Installations with high fluctuations of the flow temperature due to the heat generator (solid fuel boilers, installations with power-heat cogeneration)

3.2 3-way mixing valve [specialist]

The mixing valve (C), driven by an electric actuator, adjusts the flow temperature of the consumer circuit to the required value by means of the flow sensor and the controller.

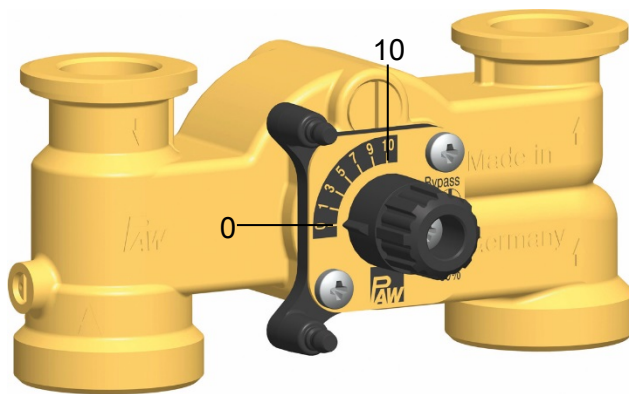

- Position 10: Passage,
no mixing,
flow temperature consumer =
flow temperature boiler
- Position 0: 100% mixing
flow temperature consumer =
return temperature consumer

Only MC43 and MC44: The mixing valve is equipped with a bypass which must be operated separately. Via this bypass, cold return water is added to the flow of the HeatBloC. This can result in an increase of the flow rate of the heating circuit.

1. During commissioning, determine the optimum bypass position for the operation of the installation through a trial-and-error process.

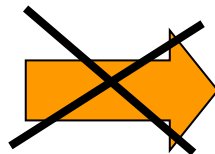

If the slot of the bypass screw is in a vertical position, the bypass is closed (normal operation).

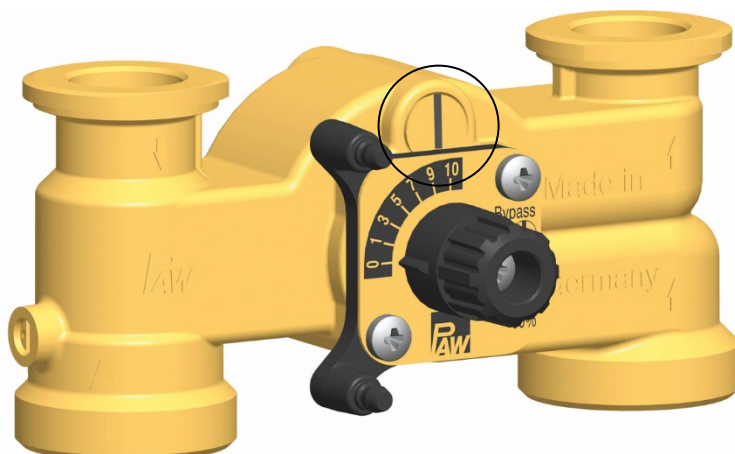

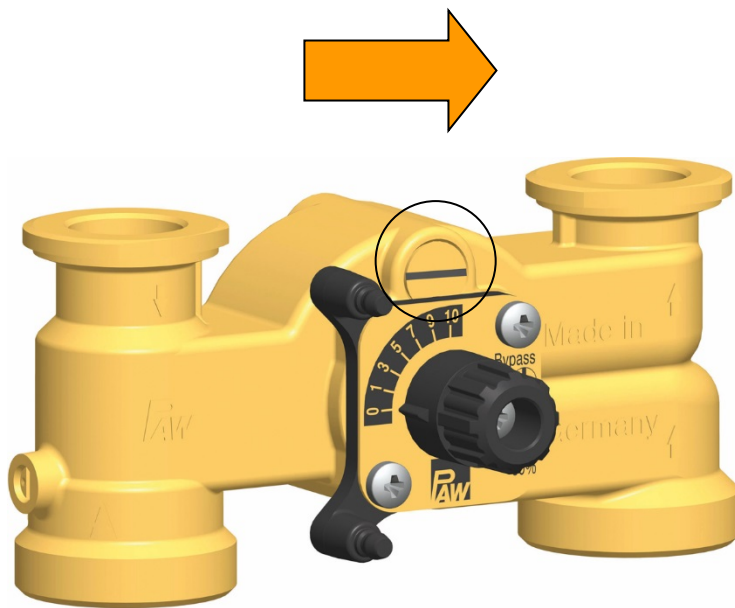

If the slot of the bypass screw is in a horizontal position, the bypass is completely open. A maximum flow rate from the return to the flow line is thus enabled.

This adjustment may be necessary for radiant floor heating systems which require a very high water flow volume. Because of the bypass, the flow temperature decreases and the control may be affected in a negative manner.

2. Check the position of the bypass during operation. Make sure that the flow rate is sufficient and that the desired temperature is reached.

3.3 Pump [specialist]

Isolation of the pump

The pump can be completely isolated. It can be replaced and maintained without draining the heating installation.

1. Close the ball valves in the flow and the return (A-2, F-2).
2. Remove the actuator from the mixing valve.
3. Only MC43 and MC44: Turn the bypass screw of the mixing valve such that the slot is in a vertical position.
4. Turn the rotary knob of the mixing valve such that the black nose is directed to "VL zu" (flow closed). In case of MC43 and MC44 the black nose of the rotary knob points to the right (position "5 o'clock"). The mixing valve is now closed and drop tight.

3.3.1 Pump settings

The pump has been correctly adjusted at the factory. In the case of a breakdown of the control (no PWM signal), the pump runs at maximum rotation speed. To assure a proper functioning of the heating circuit, the pump must be set as follows:

- PWM profile (heating)

3.3.2 Pump settings Grundfos UPM3 Hybrid

The following code must appear on the pump display. The code can be verified by briefly pressing the push button. Please observe the separate instructions of the pump!

☀️	Yellow
○	Off
○	Off
☀️	Yellow
☀️	Red
	

3.3.3 Pump settings Wilo-Yonos PARA RSTG

The rotary knob of the pump must be set to the following symbol.
The LED ring is illuminated in orange. Please observe the separate instructions of the pump!



3.4 Check valve

The HeatBloC is equipped with a check valve (D) in the return pipe and with a non-return valve (D-1) in the mixing valve. The valves can be opened.

Operation

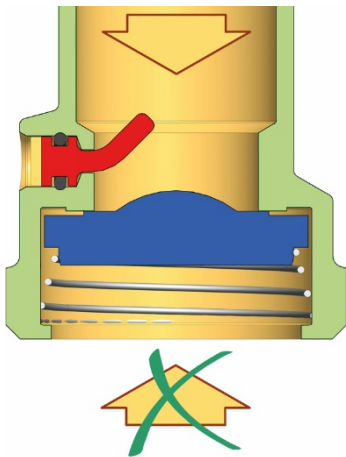

During operation, the marking must be directed to "Z".

→ The check valve is closed.

→ Flow only in the direction of the arrow.

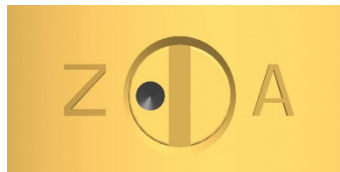

Filling, draining, venting

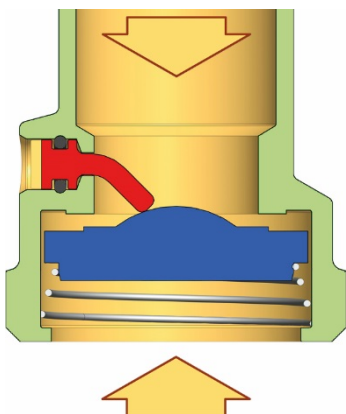

For filling, draining and venting the installation, the marking must be directed to "A".

→ The check valve is open.

→ Flow in both directions.

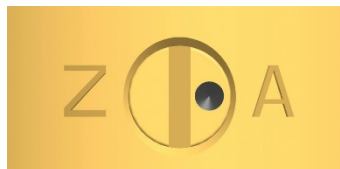

3.5 Actuator

For mixing valves with flow on the left, the scale must be turned by 180°.

Fig. 1

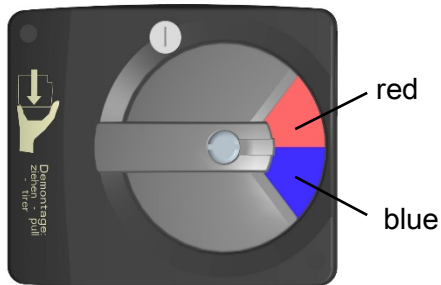

for mixing valve with flow on the left

Fig. 2

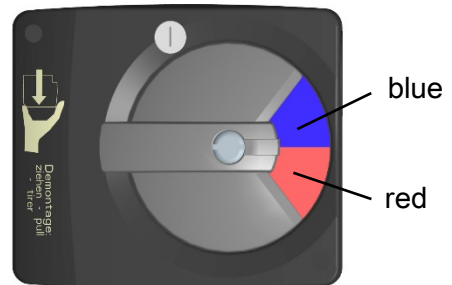

for mixing valve with flow on the right

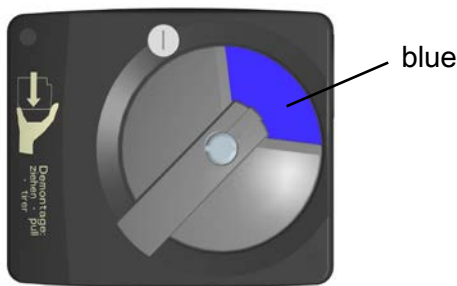

Fig. 4



Assembly of the actuator for mixing valves with flow on the right:

1. Turn the rotary knob of the mixing valve into position 0.
2. Set the actuator to manual mode by turning the selector switch.
3. Turn the rotary knob of the actuator to the left to the position shown on the adjacent figure.
4. Put the actuator on the adjusting knob of the mixing valve and the two stop bolts.
5. Set the actuator to automatic mode.

Fig. 5

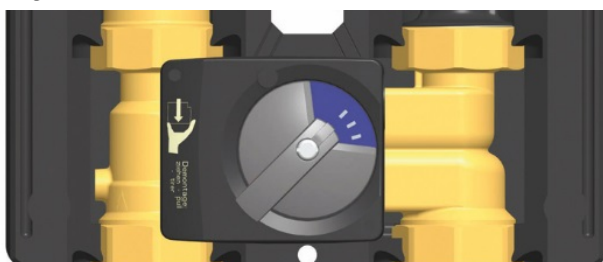

4 Change of the flow line [specialist]

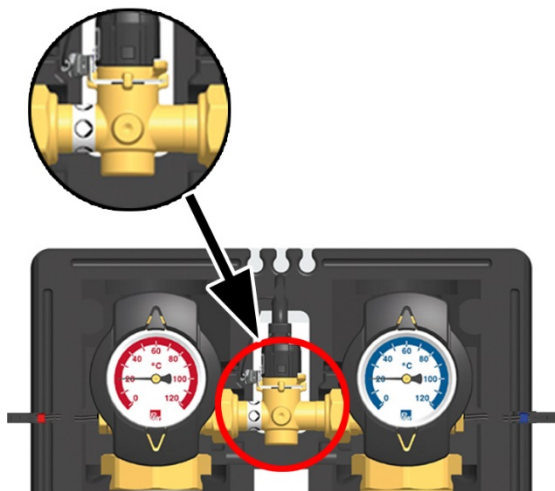
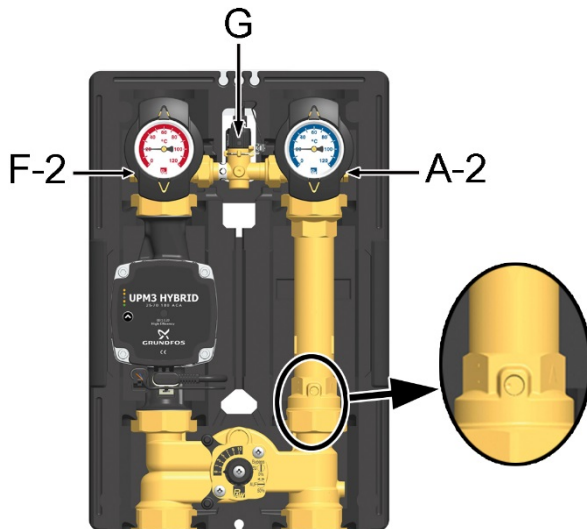

1. Dismount the temperature sensors of the ball valves (A-2 and F-2).
2. Unscrew both nuts of the sensor (G).
3. Unscrew the nuts above and beneath the pump or the return pipe.
4. Mount the return ball valve above the pump and the flow ball valve above the return pipe.
5. Dismount the mixing valve.
Retrofit the mixing valve as described in chapter 4.1 **Conversion of the mixing valve**.
6. Interchange and mount the flow and return line. Please observe the position of the opening mechanism of the check valve in the return pipe (see figure).
7. Mount the sensor (G) between the ball valves.
Attention: The ground lug of the sensor points forward. The banderole indicates on which side of the sensor housing the pump must be fixed (see figure on the left).
8. Flatten the ground lug.
9. Mount the temperature sensors T_R and T_V into the ball valves.
Observe the correct attribution:
Red = Flow
Blue = Return
10. Convert the actuator as described in chapter 3.5 **Actuator**.

11. Only MC42 and MC44: Please observe the instructions of the boiler control manual when changing the flow line.
Only MC43: Change the direction of rotation of the actuator in the MCom controller. For this purpose, open the menu "Mixing valve" > "Direction" and set "Left". Please observe the separate instructions of the controller!

4.1 Conversion of the mixing valve

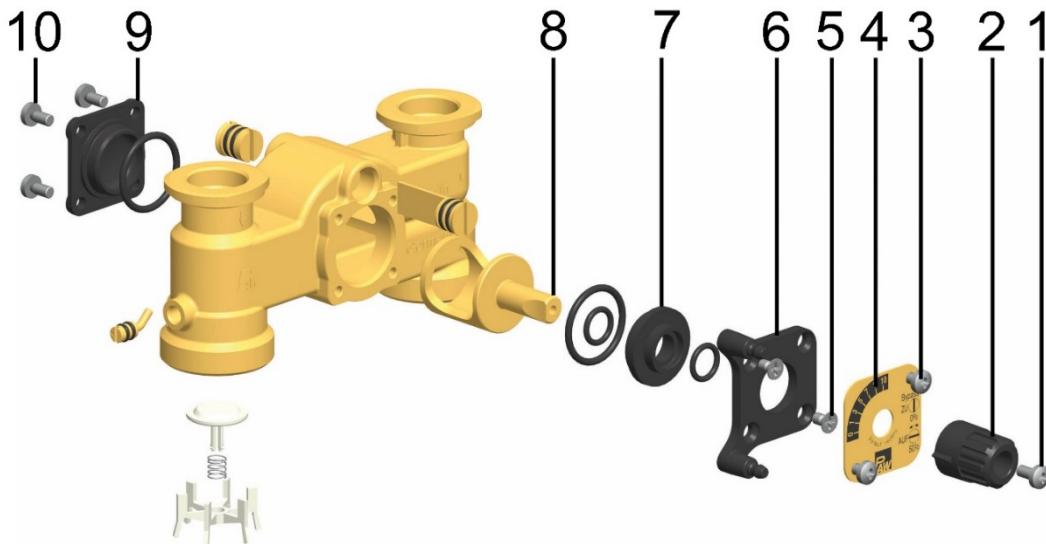

1. Loosen the screw (1).
2. Take off the rotary knob (2) from the cock rod.
3. Loosen the screws (3).
4. Remove the cover plate (4).
5. Loosen the two screws (5).
6. Remove the front plate (6).
7. Extract the sealing bush (7) and the valve cock (8) from the mixing valve housing.
8. Loosen the screws (10) on the rear side of the mixing valve.
9. Take off the cover (9) on the rear side of the mixing valve and fix it on the other side of the mixing valve by using the screws (10).
10. Insert the sealing bush (7) and the valve cock (8) into the channel of the mixing valve.
11. Fix the front cover (6) by using the screws (5).

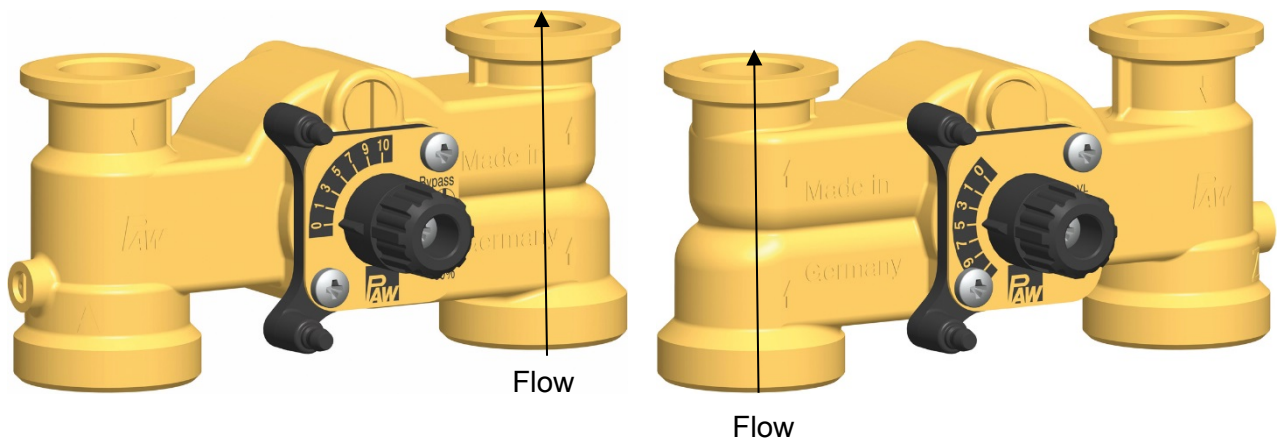

Mixing valve with flow on the right

Mixing valve with flow on the left

12. Turn the cover plate (4) such that the marking PAW is at the bottom and that the scale is positioned as shown on the figure above.
13. Fix the cover plate (4) by using the screws (3).
14. Put the rotary knob (2) onto the cock rod.
15. Fix the rotary knob (2) on the cock (8) by using the screw (1).

5 Assembly and installation [specialist]

The PAW HeatBloC must be either installed on a PAW modular distribution manifold or a PAW wall bracket. Please observe the separate instructions!

NOTICE

Damage to property!

The location of installation must be dry, load-carrying, frost-proof and protected against ultraviolet radiation in order to prevent material damage of the installation.

5.1 Installation and commissioning of the HeatBloC

The HeatBloC MC can be mounted on a PAW modular distribution manifold.



NOTICE

- Verify if the grounding cable holds securely in place at the differential pressure sensor!
The ground lug points in the direction of the banderole.
- Carry out the following mounting instructions in parallel at each heating circuit of the system.

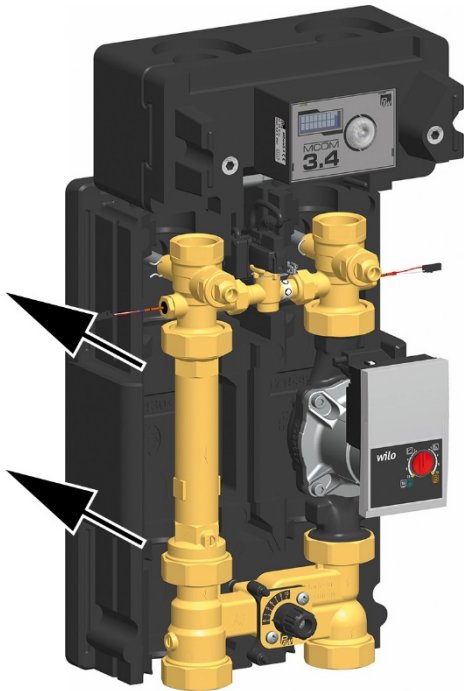

1. Remove the station from the packaging.
2. Take off the thermometer handles.
3. Note regarding HeatBloC with Wilo pump:
Dismount the insulating front shell of the controller and push the insulating back shell backwards.
4. Remove the actuator.
5. Take off the insulating front shells.
6. Push the insulating back shell backwards.

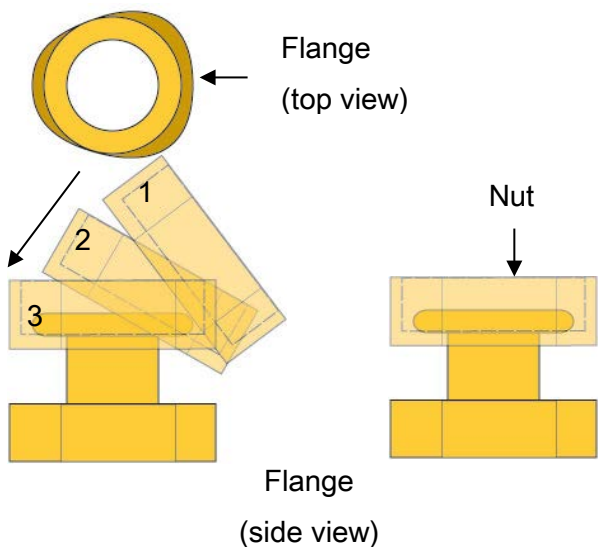

7. Unscrew the nuts on the lower connections of the HeatBloC and take out the sealing rings.
8. Put the two nuts over the flanges of the distribution manifold.

Sealing ring

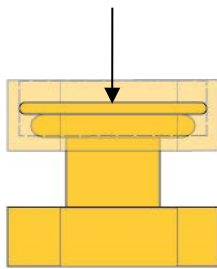

9. Put the sealing rings on the sealing surfaces.
10. Put the HeatBloC onto the two sealing rings.
11. Tighten the nuts.
Make sure that the nuts do not get jammed and that the sealing rings do not slip.
12. Connect the HeatBloC to the installation by using the pipes. The installation to the piping must be carried out without any tension.
13. Repeat these steps for all the HeatBloCs that are mounted.
14. Fill and vent the installation.
15. Carry out a pressure test and check all thread connections.
16. Check the position of the check valve: during operation, the marking must be directed to "Z" (see page 11).
17. Mount the insulating back shell.
18. Run first the cable of the actuator through the insulating element of the mixing valve backwards. Mount the insulating element. Mount the actuator (see page 12) and pull the actuator cable backwards at the same time.
19. Connect the power supply of the pump and the actuator (only MC42 and MC44) to the heating controller.
20. Flush the installation.
21. Mount the insulating front elements.
22. Mount the insulating front and back shell of the distribution manifold.

5.2 Cabling

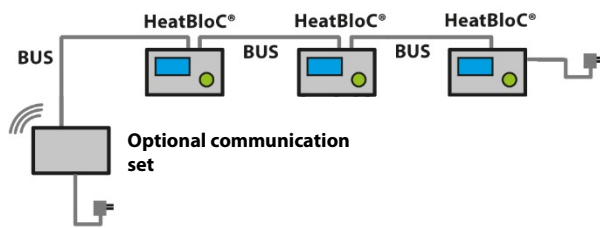

1. Loosen the screws of the controller insulation.
2. Dismount the insulating front shell of the controller.
3. Connect the wall power supply to the socket X6.2 (see below) at the last (right) controller.
4. Connect the bus line from controller 1 to controller 2 in the socket X6.1.
As the two sockets of the bus line (X6.1 and X6.2) are connected in parallel, the position has no importance.
5. Repeat these steps for all the HeatBloCs that are mounted.
6. Remove the bus line from the last controller. Keep the bus line as spare part.

X1	X2	X3	X4	X5	X6.1	X6.2
X1	Only MC43: Signal of the actuator			X4	Temperature sensor T_V , flow, red marking	
X2	PWM signal of the pump			X5	Differential pressure sensor	
X3	Temperature sensor T_R , return, blue marking			X6.1	Supply voltage or bus line (connected in parallel and therefore interchangeable)	
				X6.2		

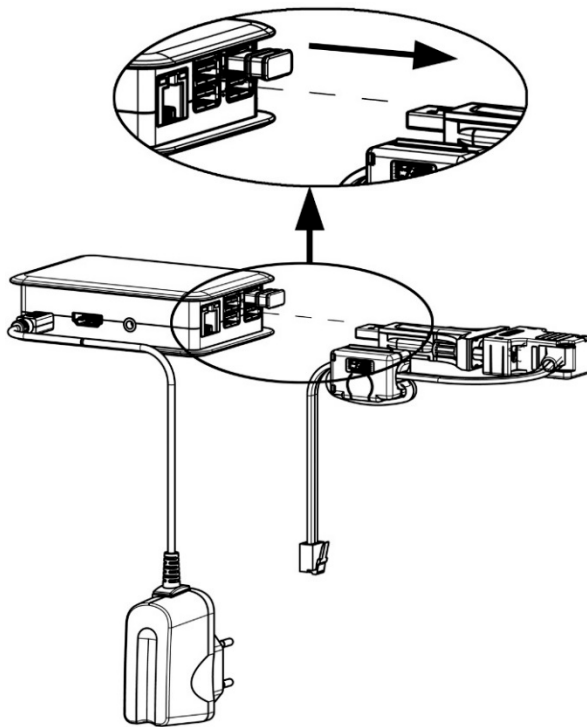

7. If you do not mount the communication set, continue at point 11.
8. If you additionally mount the optional communication set, run the bus line of the communication set to the first (left) controller. For this purpose, disconnect the plug of the bus line from the mini PC of the communication set.
9. Make sure that the plug does not get wet.
10. Mount the optional communication set now. Please observe the separate instructions of the communication set!
11. Carry out the electrical commissioning of the controllers (see controller instructions).



12. Carry out the electrical commissioning of the communication set (see instructions of communication set).
13. Mount the insulating front shell of the controller.
14. Screw the screws in the controller insulation.

15. Please fill in the enclosed insert
and fix it on the insulation:

HeatBloC® MC	
Typ:	MC42
Name:	Radiant panel heating, 1st floor
No:	2
 www.paw.eu	

Type:	Type of the heating circuit, f. ex. MC42
Name:	Type of the application and floor, f. ex. radiant panel heating, 1st floor
No.:	Number of the heating circuit according to the controller instructions, f. ex. 2

5.3 Accessories

5.3.1 Connection set (not included in the scope of delivery)

For the connection of the MCom controllers to the power supply **one** connection set (wall power supply, item no. 1398700) is mandatory, regardless of the number of heating circuits.

5.3.2 Communication set (not included in the scope of delivery)

The communication set with insulated housing can be mounted on the distribution manifold or on the wall using the enclosed mounting rail. It is connected with the controllers via a bus line. The internal mini PC is equipped with a power supply unit to assure the power supply and establishes its own local WLAN network. With a smartphone and the corresponding PAW MCom app, you can establish a connection with your installation via this WLAN and set parameters or read out current values.

You will get the app in the App Store for iOS devices and in the Google Play Store for Android devices entering the search term "PAW MCom".

5.3.3 Cutting-ring compression fitting (not included in the scope of delivery)

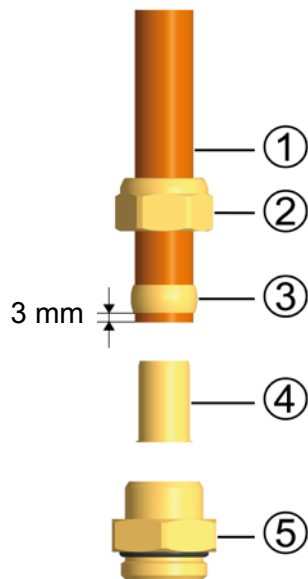

Not included in the scope of delivery!

1. Push the union nut ② and the cutting ring ③ onto the copper pipe ①. The pipe must protrude at least 3 mm from the cutting ring in order to ensure the force transmission and the sealing.
2. Insert the support sleeve ④ into the copper pipe.
3. Insert the copper pipe with the plugged-on individual parts (②, ③ and ④) as far as possible into the housing of the compression fitting ⑤.
4. First, screw the union nut ② manually.
5. Tighten the union nut ② by rotating one full turn. Secure the housing of the compression fitting ⑤ against distort, in order to avoid damaging the sealing ring.

5.3.4 Wall bracket set for wall assembly (not included in the scope of delivery)

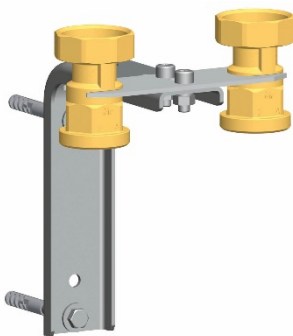

Description	Item no.
Wall bracket set DN 25	3422SET
Wall bracket set DN 32	3722SET

6.2 Hydraulics DN 25

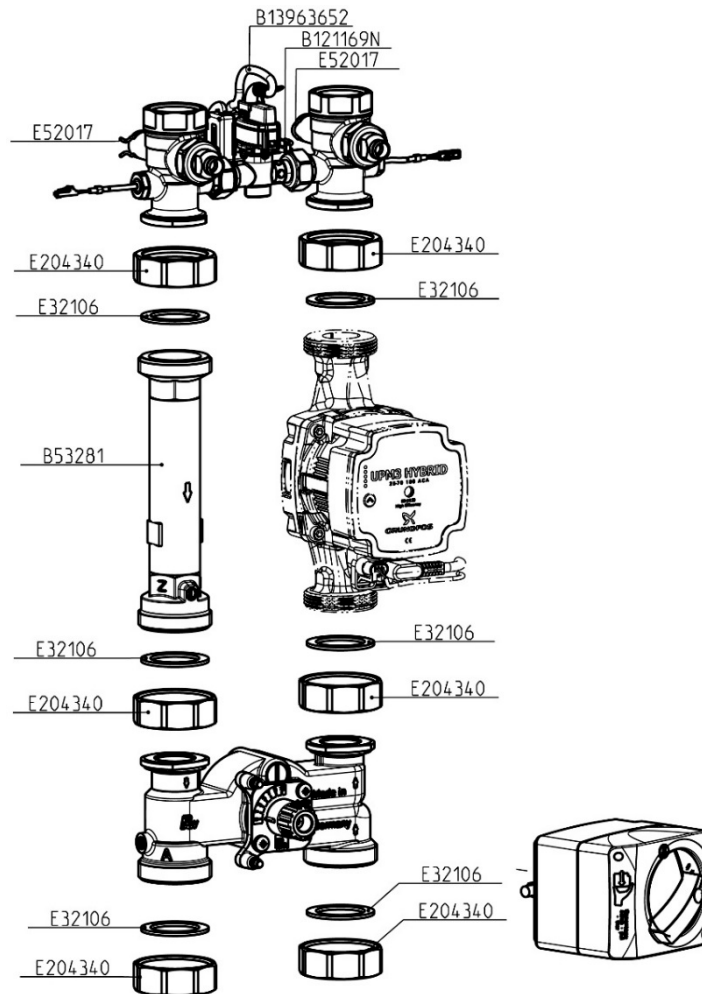

Item	Item number	
Sealing set for mixing valve MC42	34013	
Sealing set for mixing valve MC43/44	37013	
Pump		EEI
Grundfos UPM3 Hybrid 25-70	E1212465F	< 0.20
Wilo-Yonos PARA RSTG 25/1-7.5	E1236247	< 0.21
Mixing valve		
MC42: 3-way mixing valve	B340126	
MC43/MC44: 3-way mixing valve with bypass 0-50%	B340516	
Actuator		
MC42/MC44: PAW actuator SR5 - 5 Nm, 230 V	705001	
MC43: PAW actuator SR10 24/3P - 10 Nm, 24 V	7054	

6.3 Insulation and controller DN 32

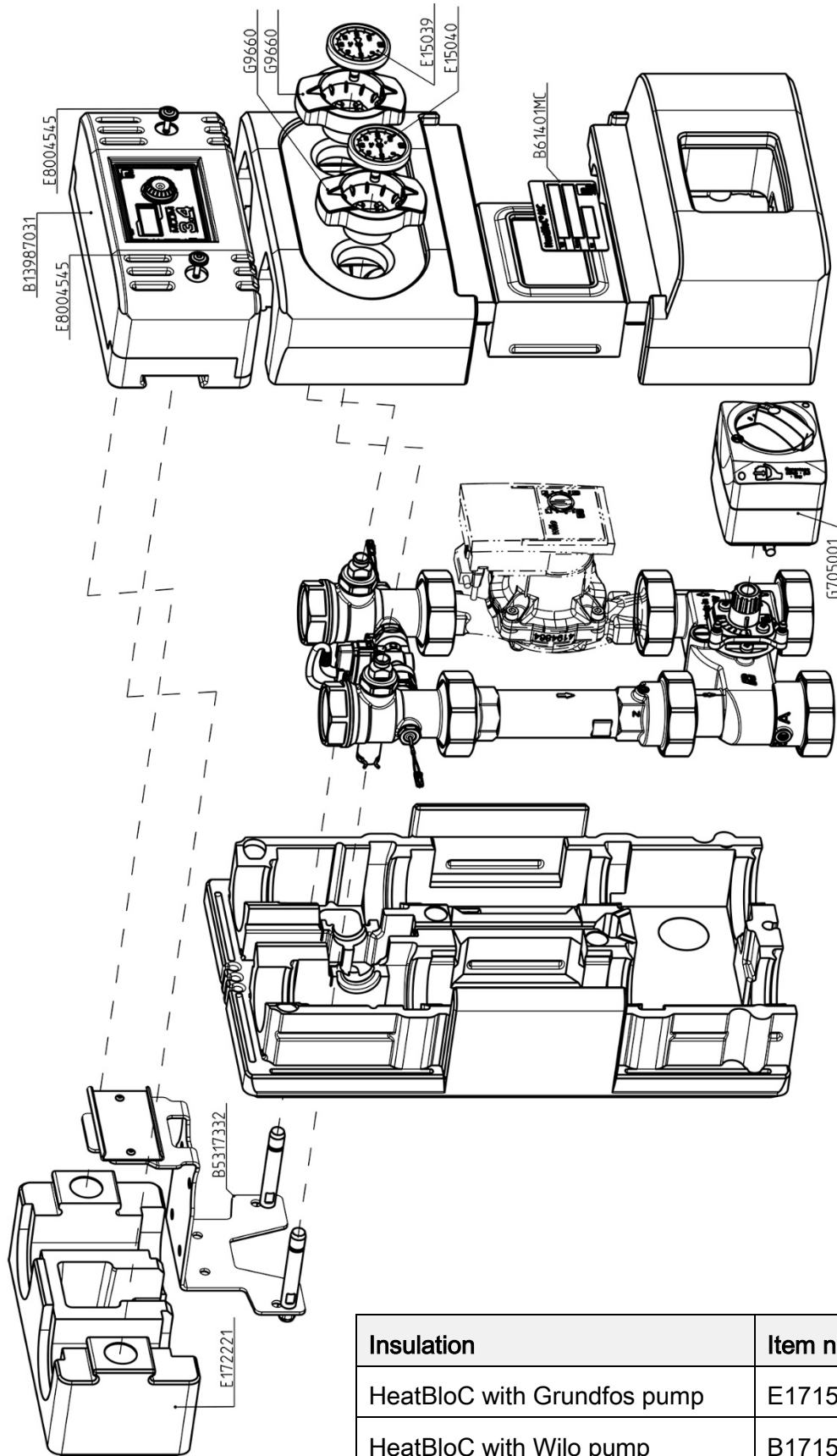

Insulation	Item no.
HeatBloC with Grundfos pump	E171593
HeatBloC with Wilo pump	B1715933

6.4 Hydraulics DN 32

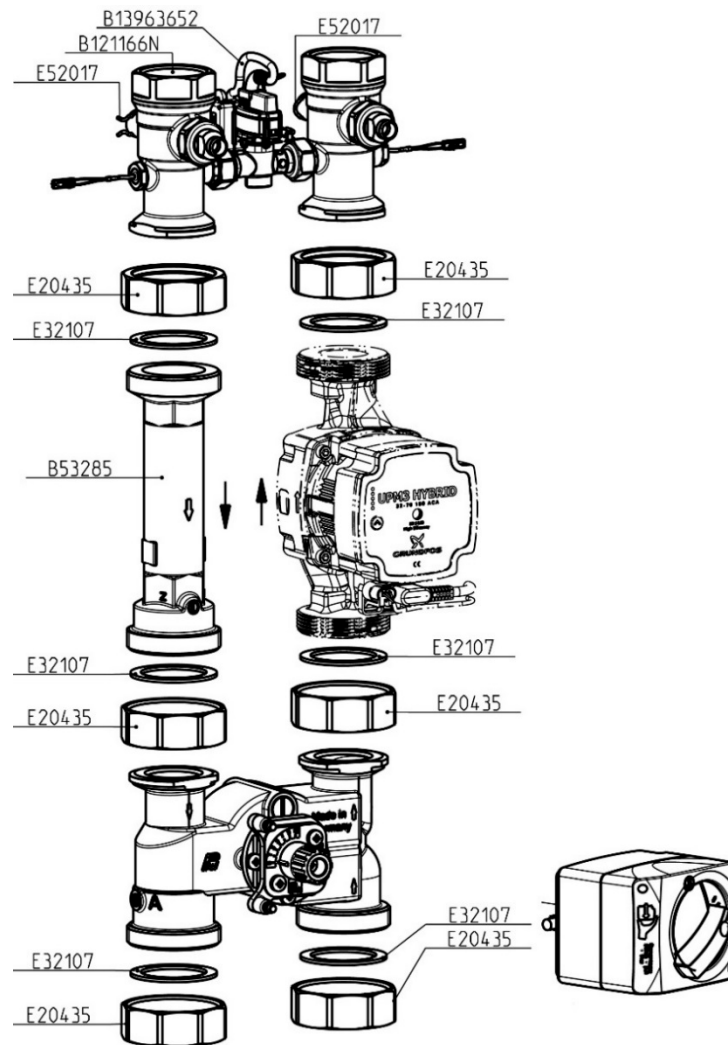

Item	Item number	
Sealing set for mixing valve MC42	37013	
Sealing set for mixing valve MC43/44	41013	
Pump		EEl
Grundfos UPM3 Hybrid 32-70	E1212565F	< 0.20
Wilo-Yonos PARA RSTG 30/1-7.5	E1236257	< 0.21
Mixing valve		
MC42: 3-way mixing valve	B370126	
MC43/MC44: 3-way mixing valve with bypass 0-50%	B370516	
Actuator		
MC42/MC44: PAW actuator SR5 - 5 Nm, 230 V	705001	
MC43: PAW actuator SR10 24/3P - 10 Nm, 24 V	7054	

7 Technical data

	DN 25 (1")	DN 32 (1¼")
Dimensions		
Centre distance	125 mm	125 mm
Width insulation	250 mm	250 mm
Height insulation	500 mm	557 mm
Installation length	340 mm	400 mm
Connections		
Connection generator	1½" external threads, flat-sealing	2" external thread, flat-sealing
Connection consumer	1" internal thread	1¼" internal thread
Technical data		
Opening pressure check valve	200 mm wc, can be opened	
Materials		
Valves and fittings	Brass	
Gaskets	AFM34 / EPDM	
Insulation	EPP, EnEV conform	
Hydraulics		
Maximum pressure	6 bars	
Maximum temperature	110 °C	
K _{VS} value [m³/h]		
MC42	5.2	9.6
MC43 / MC44	6.0	10.1

7.1 Dimensional drawing DN 25

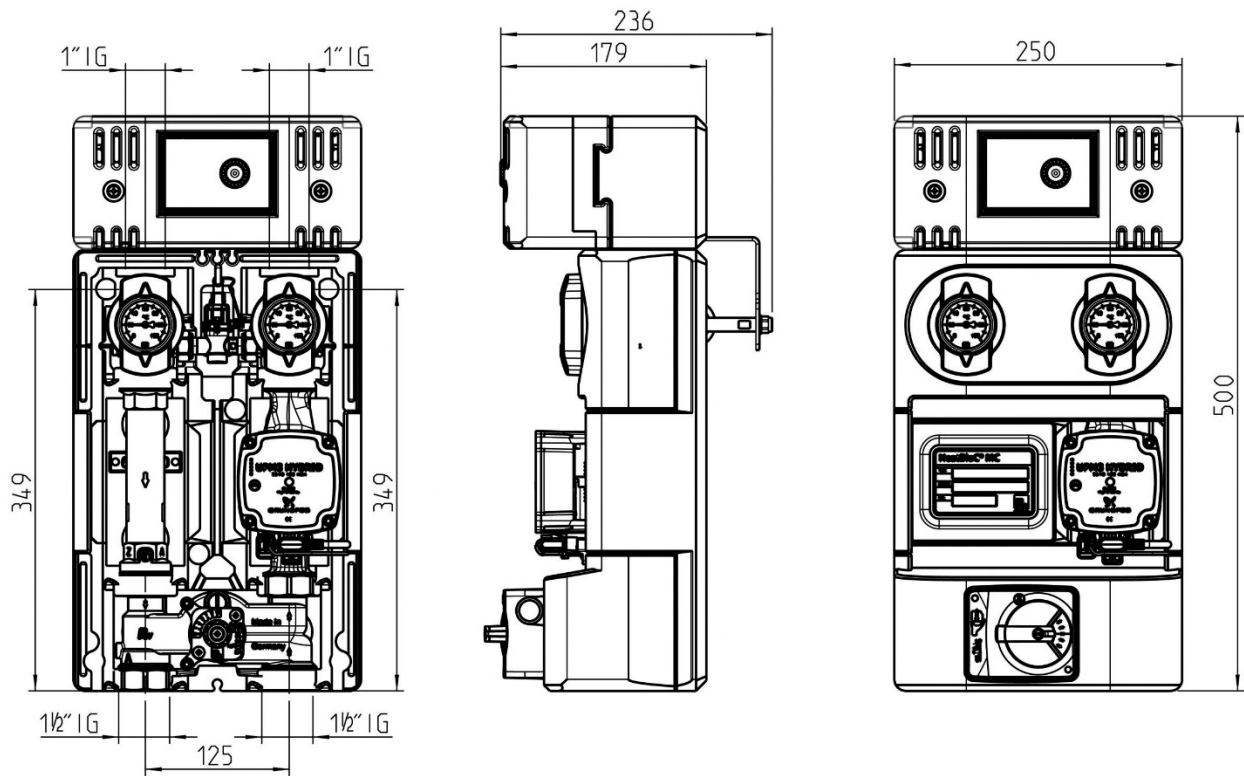

7.2 Dimensional drawing DN 32

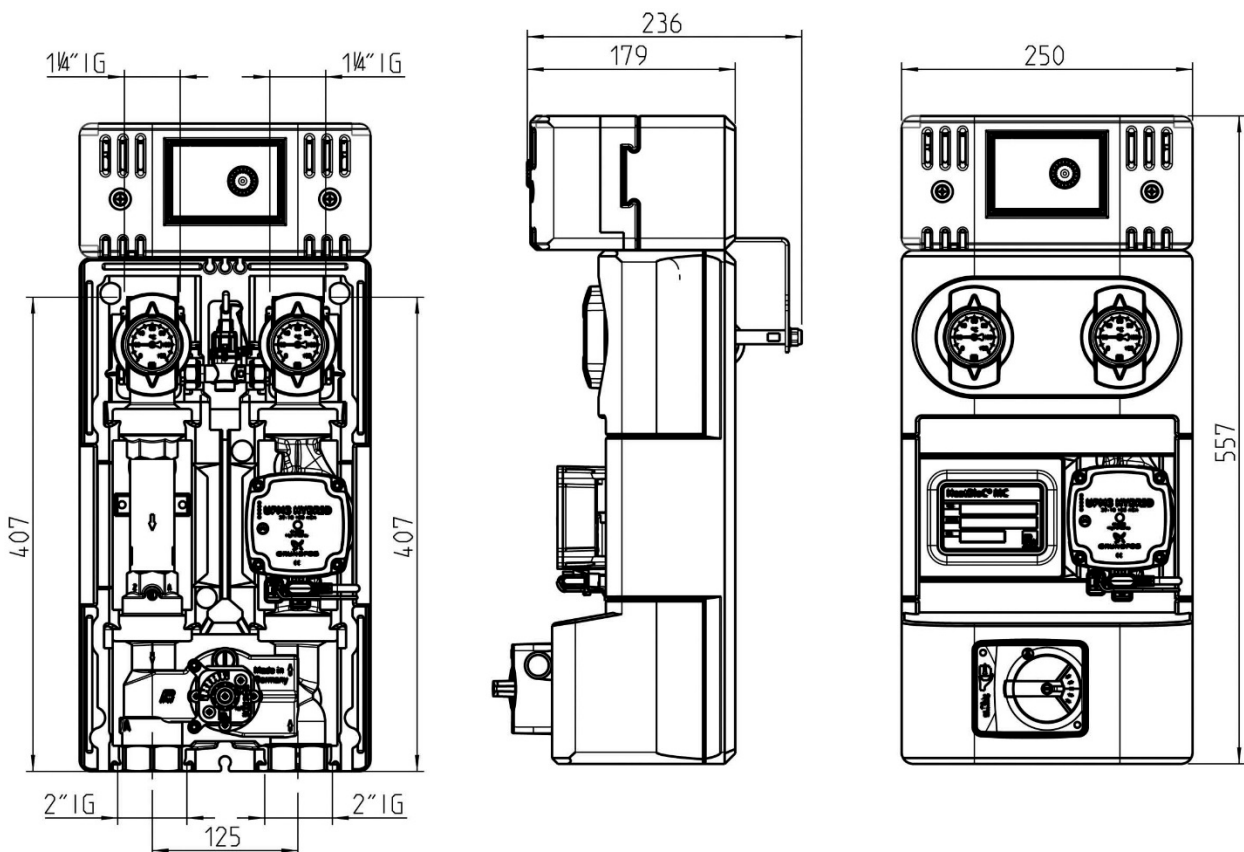

7.3 Pressure drop and pump characteristic curves MC42

DN 25:

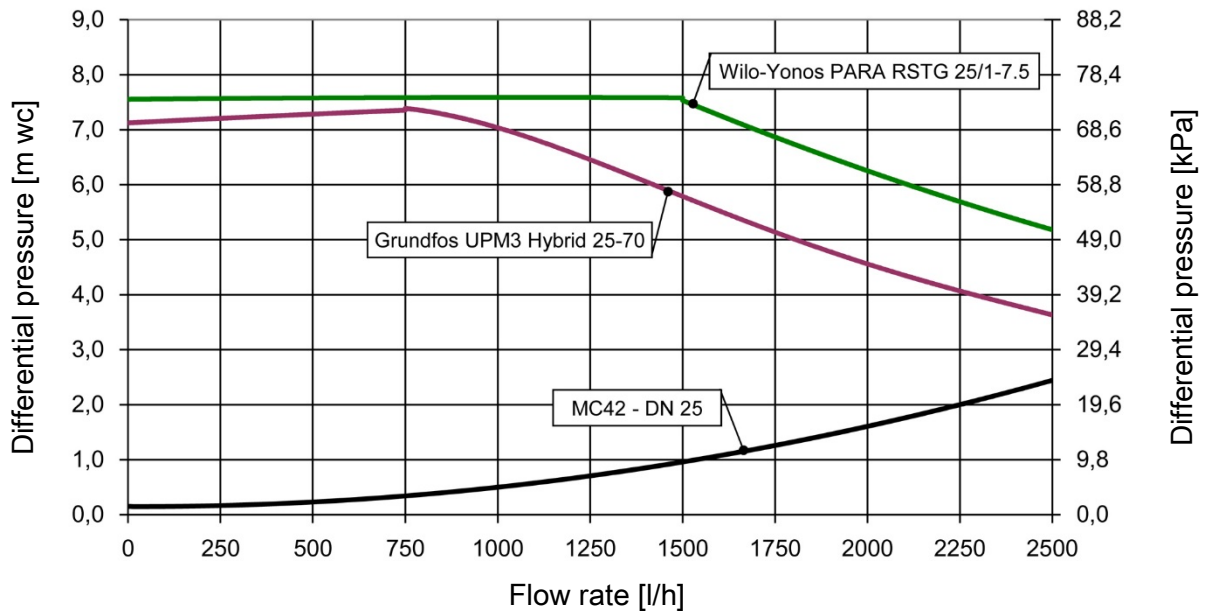

DN 32:

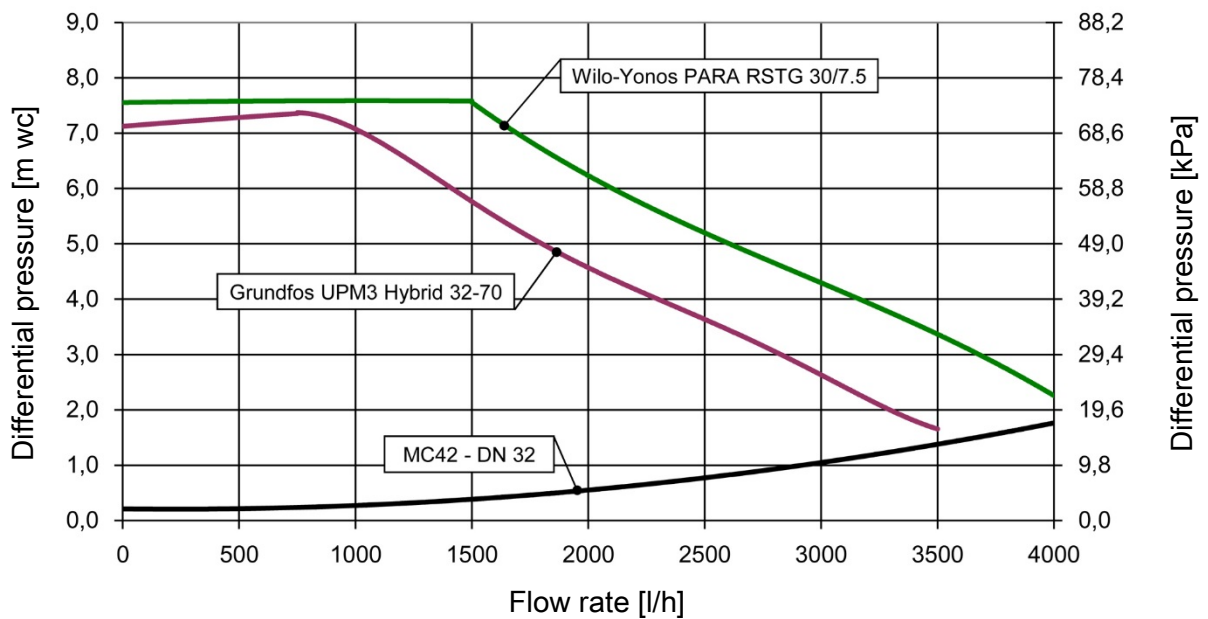

7.4 Pressure drop and pump characteristic curves MC43/MC44

DN 25:

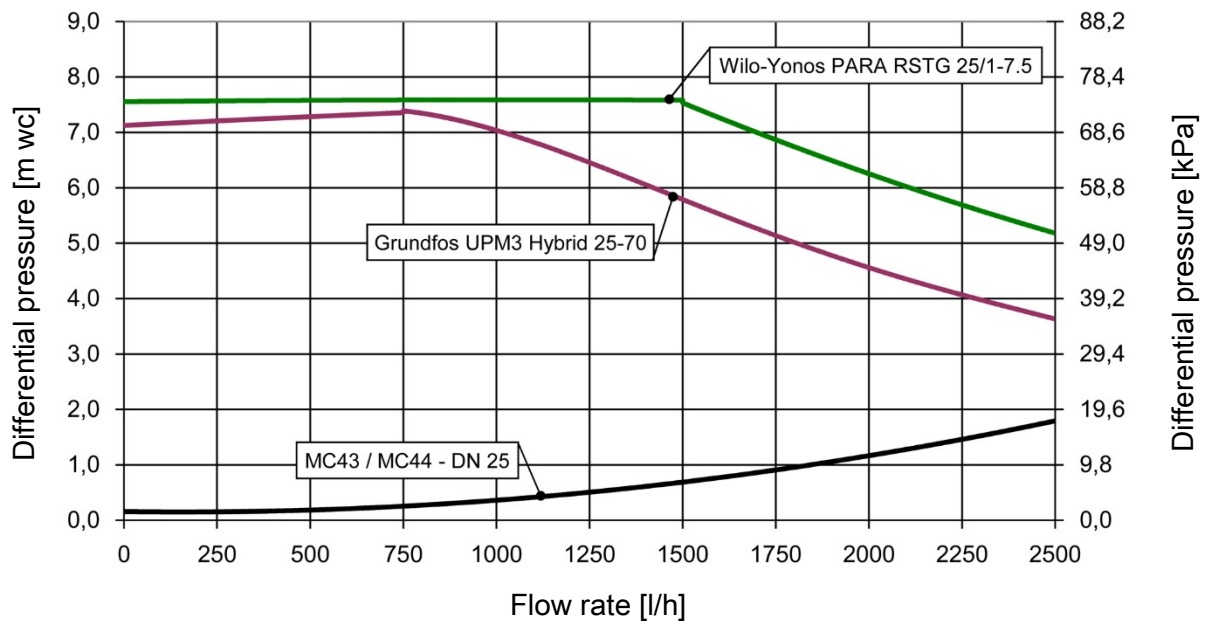

DN 32:

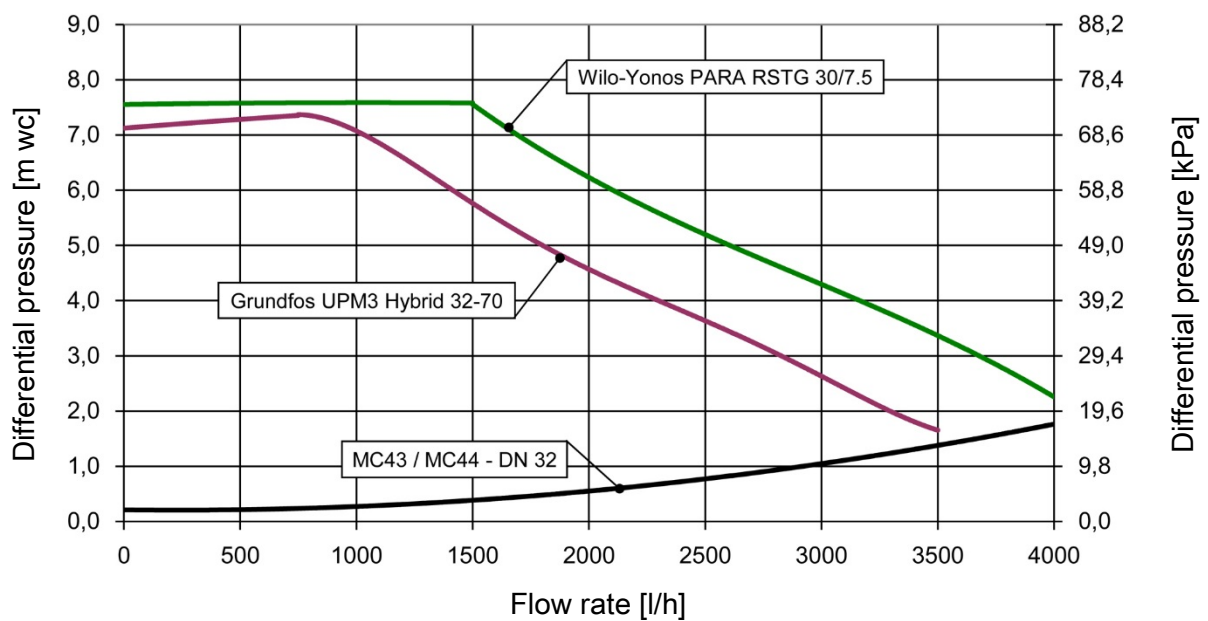



PAW GmbH & Co. KG

Böcklerstraße 11

D-31789 Hameln, Germany

www.paw.eu

Phone: +49 (0) 5151 9856 - 0

Fax: +49 (0) 5151 9856 - 98